

See discussions, stats, and author profiles for this publication at: <https://www.researchgate.net/publication/334164398>

Application of Linear Sensitivity Factors for Real Time Power System Post Contingency Flow

Article · July 2019

CITATION

1

READS

897

3 authors, including:



John Ulasi

Chukwuemeka Odumegwu Ojukwu University, Uli

7 PUBLICATIONS 4 CITATIONS

[SEE PROFILE](#)



J.P. I. Iloh

Chukwuemeka Odumegwu Ojukwu University

18 PUBLICATIONS 9 CITATIONS

[SEE PROFILE](#)

Some of the authors of this publication are also working on these related projects:



Power Generation Statistics for Nigeria [View project](#)



Municipal Energy Management System Using Distribution Network Automation and Dynamic Price Model [View project](#)

Application of Linear Sensitivity Factors for Real Time Power System Post Contingency Flow

A. J. ULASI¹, J. P. I. ILOH², O. K. OBI³

¹Dept. of EEE, Chukwuemeka Odumegwu Ojukwu University, Uli Campus, Nigeria
^{2,3}Dept. of EEE, Chukwuemeka Odumegwu University, Uli Campus, Nigeria

Abstract- Linear sensitivity factors are methods in sensitivity analysis, used in determining the effect of power system component variations on the remaining part of the system. This study presents the application of linear sensitivity factors for real time power system post contingency flow determination. The Power Transfer Distribution Factor (PTDF) was used to predict the proportion of power that will flow on a line after a transfer of power has occurred from one bus to another. The Line Outage Distribution Factor (LODF) was used to predict the proportion of power that will flow on a monitored line due to an outage of another power line. The study implemented the use of these sensitivity factors on a six bus sample case and the result from this showed that when there was a transfer of 50MW power from generator at bus 1 to bus 2, the line flow on line index 2 increased from 76.66MW to 92.41MW which is near the thermal limit of 100MVA, but in line index 2 there was an output reduction in flow from 50MW to 35MW on bus 2 generation. The study achieved its purpose of applying linear sensitivity factor to determine the real time power system post contingency flow with the help of MATPOWER which is an embedded program in MATLAB simulator. Similarly the result of the post outage line flow on line index 8 as a result of the outage of line index 6 was calculated using the LODF sensitivity factor to be 18.29MW while the pre outage flow was 12.54MW. These values tallied exactly with the value obtained using the conventional DC load flow calculation. Therefore the study ascertained that it is faster and more reliable to use these sensitivity factors to resolve power system load flow problems rather than going through the conventional load flow methods. The study also has been able to contribute to knowledge, by proposing a linear sensitivity analysis method that can relate to expected real time load value, in relation to component variations, as well as operating limit verification. Post-contingency ranking of power system network in order of their severity is one of the recommended areas of which this work could be applied.

Indexed Terms - Cognitive Power flow, Contingency, PTDF, LODF

I. INTRODUCTION

There are limitations in the operation of power system. Due to the interconnected nature of the power system, it is the responsibility of the system operators to ensure system reliability. A power system is said to be secured if it withstands a set of severe but credible contingencies and return to an acceptable new steady state condition. This is assessed by detection of operating limit violation and contingency analysis (Ameze, 2013). The cost of power system operation has been of most priority beyond the planning stage of any power system. However, the maintenance of such designs requires that the security of the system and its components is never compromised. Power system security as defined by Allen (2005), comprises all practices designed to ensure that the system maintains operation despite a component failure. In the event of a fault or during maintenance, any part of the system could be taken out at any time due to the interconnected nature of the power grid. How the system responds to the aftermath of an outage of a component on account of failure or maintenance constitutes a sensitivity challenge.

The impact of changes in system parameters on system performance can be measured by sensitivity analysis. Sensitivity analysis can also be used to calculate changes in branch flows, losses, bus voltage due to variations in generation and loads. In many cases that deal with reactive power injection, the variation in voltage with respect to change in reactive power injection has been used to calculate sensitivity factor. Sensitivity analysis is a major criterion for determining the priority chart for voltage control in a

distribution network with distributed generators inserted (Bhat, 2015).

The recurrent surge in power system load has resulted in the operation of power system under stressed conditions, where the transmission lines are operating near the security limit levels (Chong, 2011). Power system equipment are designed to be operated within certain limits. If any event occurs in the system and these limits are violated the event may be followed by a series of multiple failures, a large part of the system may completely collapse (Onojo, 2016). The outage of certain components during certain operation could result in a significant alteration of the state of the entire power system. For instance, the outage of a heavy loaded transmission line connected to a load center means significant widespread blackout at the load center leading to customer dissatisfaction. The sudden outage of a large generator may lead to undesired voltage profile containing violations across a number of nodes which will eventually lead to voltage collapse or other forms of operational instability.

Outages of components whether forced (as in the case of faults) or scheduled (for maintenance or repairs) do not always lead to violations of set limits on transmission lines or buses. In other words, each component outage has a unique implication which is largely dependent on the component defined limits, its role and the condition of system operation. Therefore, a comprehensive knowledge of the network components and their condition of operation at the levels of design, planning and operation is vital for reliable supply. To this end, linear assessment methods are employed. One of such methods is sensitivity analysis which measures the sensitivity of a line component with respect to an outage or variation of flow on another transmission line or from generator at a node.

The word sensitivity is defined as the degree of response of a receiver or instrument to an incoming signal or to a change in the incoming signal, as in FM radio (Harcourt, 2018). Thus it is actually the degree of response of a system, to a change in the input signal. Sensitivity analysis can be defined as a tool that finds out how sensitive an output is to any change in an input while keeping other inputs

constant (Rosa, 2014). In other words it determines the impact or effect of a particular system component variation and how the system changes from a known or desired state. It also provides a measure of the amount of load to be curtailed in response to the violation of the operating limits or component characteristics (Ben-Idris, 2014). This enables the system planner or operator, to determine how the entire system would respond to a change and in this case of an outage, whether forced or scheduled.

Linear sensitivity factors are mainly Power Transfer Distribution Factors (PTDF_S) and the Line Outage Distribution Factors (LODF_S). Linear sensitivity factors are preferred on the account of the ease and speed of calculation of possible overloads especially when studying numerous possible outages. Power distribution factor is a factor used in allocating megawatt flows on the lines for power transaction (transmission or transfer of power from one bus to another through a transmission line) in the system. This power transfer distribution factor (PTDF) is the relative change in the power flow on a particular line due to an injection and withdrawal of power on a pair of buses (Chong, 2011). While line outage distribution factor (LODF) on the other hand describes the flow changes on a transmission line when one line fails. LODFs can be viewed also as linear estimates of the change in flow on adjacent lines with the outage of transmission lines (Chong, 2011).

Significantly, this study brings about solutions that can relate in real time the impact of various system contingencies on the transmission line. The desire to reduce computational time, for evaluating these contingency events in the planning and operation of the power system reliably is of great importance. Also to observe how sensitive the grid components are to output variations or outages in post-contingency power system analysis. This study intends to provide answer to the question of what will flow on the transmission line after a contingency of a generator or a transmission line has occurred? Is it possible to predict a post-contingency line flow, to identify possible limit violation and estimate the margin of violation from a current operational state following a grid component contingency?

The availability of such knowledge makes it possible to know the level of system violations due to these contingencies. These violations could be screened and ranked in order of their different degrees of severities. System planners and power system operators could use such information, to implement preventive or remedial actions, to correct and prevent the impact of possible violations due to contingency of generator or transmission line in the power system.

II. POWER SYSTEM LINEAR SENSITIVITY FACTORS

The idea of sensitivity analysis in power systems has been widely used to avoid recalculation of the power flow solution. In transmission systems, the parameters used in these analyses are the power transfer distribution factors (PTDF) and the line outage distribution factors (LODF). PTDFs are defined as the changes in the line power flows due to a change in power injection at a particular bus. LODFs are defined as the changes in the line power flows due to the disconnection of a particular line (Wood & Sheble, 2014). The calculation of these sensitivity factors has gained more interest recently due to the need for fast online readjustments in modern power systems.

Cascading failures, which are sequence of component outages that include at least one triggering component outage and subsequent tripping component outages due to the overloading of transmission lines and situational awareness of human operators (Chao Zhai, 2018). These have been the major issues deteriorating the reliability of the

power system thereby requiring measures to revert the power flow on overloaded lines.

When a single line fault or a multiple line fault occurs in the system, the power is shifted to the adjacent transmission lines. This normally results in unfavorable operation conditions where the transmission lines are being overloaded i.e. transferring power above its capacity thereby resulting in cascading faults. In order to avoid such a situation, the overloaded lines need to be relieved from the extra load. A security analysis must be executed very quickly in order for it to be of any use to the operators. This is where the computation of the distribution factors such as the PTDFs and LODFs are required. These factors, which are based on the DC power flow method, provide approximate but quick solutions for the change in the power injections in the system (Chong, 2011).

The problem of studying thousands of possible outages become very difficult to solve if it is desired to present the result quickly. One of the easiest ways to provide a quick calculation of possible overloads is to use linear sensitivity factors. These factors show the approximate change in line flows for changes in generation on the network configuration and are derived from the DC load flow. These factors can be derived in a variety of ways and basically come down to two types namely Power Transfer Distribution Factors (PTDFs) and Line Outage Distribution Factors (LODFs)

III. POWER TRANSFER DISTRIBUTION FACTORS (PTDF)

The PTDF factors are expressed mathematically as

$$PTDF_{ikt} = \frac{\Delta f_t}{\Delta P} \quad (1)$$

Where

t = Monitored transmission line index

i = Bus where power is injected (contingency bus)

k = Bus where power is taken out (post-contingency bus)

ΔP = Power transferred from bus i to bus k

Δf_t = Change in megawatt power flow on line t when ΔP is made between i and k

Then the post outage flow can be derived using

$$\hat{f}_t = f_t^0 + \text{PTDF}_{i,kt} \Delta P \quad (2)$$

For $t = 1, 2, 3, \dots, l$

Where

\hat{f}_t = post contingency real power flow on transmission line t (post outage flow)

f_t^0 = Pre-contingency real flow on transmission line t (pre outage flow)

Suppose it is desired to study the outage or output-reduction of a large generating unit assuming that all the generation lost on account of the contingency or output reduction of this generator would be taken up by the reference generator connected at the slack bus. If the pre-contingency and post-contingency generations are P_i^0 and P_i^r then the change in generation for the lost is expressed as

$$\Delta P = P_i^r - P_i^0 \quad (3)$$

If the lost generators pre-outage generation is $P_E^0 = 20\text{MW}$, the post-outage generation will be $P_E^r = 0\text{MW}$.

Therefore change in power $\Delta P = P_E^r - P_E^0$, will be post-outage generation minus pre-outage generation (i.e. $0\text{MW} - 20\text{MW}$) which will result to -20MW , and this justifies

$$\hat{f}_t = f_t^0 + \text{PTDF}_{i,ref,t} \Delta P \quad (4)$$

Note that in this case, “ref” was substituted for “k” to indicate that the shift is from bus i to the reference bus.

Once the “post outage flow” \hat{f}_t on each line has been gotten, each may then be compared to its pre-specified secure limit and those exceeding their limits flagged for alarming. This would inform and equip system operation personnel on the overloading implication of a transmission line t on account of the loss of a generator at i .

The PTDF factors are linear estimates of the change in flow on a line with a shift in power from one bus to another. Therefore, the effects of simultaneous changes on several generating buses can be calculated using superposition.

Suppose, for example, that the loss of the generator on bus i were compensated by governor action on synchronous generators throughout the interconnected system. One frequently used method assumes that the remaining generators pick up in proportion to their maximum MW rating. Thus, the proportion of generation pickup from unit $x(x \neq i)$ would be

$$Y_{ix} = \frac{P_x^{\max}}{\sum_{k \neq i} P_k^{\max}} \quad (5)$$

Where

P_k^{\max} = Maximum MW rating for generator k

Y_{ix} = Proportionality factor for pickup on generating unit x when unit i fails

Then, to test for the flow on line t , under the assumption that all the generators in the interconnected system participate in making up the loss, use the following:

$$\hat{f}_t = f_t^0 + \text{PTDF}_{i,ref,t} \Delta P_i - \sum_{x=1} [\text{PTDF}_{ref,x,t} Y_{ix} \Delta P_i] \quad (6)$$

Note that this assumes that no unit will actually hit its maximum.

IV. LINE OUTAGE DISTRIBUTION FACTORS (LODFS).

The LODF factors are used in a similar manner, only they apply to the testing for overloads for post transmission line contingency. By definition, LODF can be expressed mathematically as,

$$LODF_{m\ell} = \frac{\Delta f_m}{f_\ell^0} \quad (7)$$

Where

ℓ = Outaged transmission line index

m = Monitored transmission line index

$LODF_{m\ell}$ = Line outage distribution factor of the monitored line m after an outage of line ℓ

f_m^0 = Pre-contingency/pre-outage flow on line m , before line ℓ was outaged (opened)

f_ℓ^0 = Pre-contingency/pre-outage flow on line ℓ before it was outaged (opened)

Δf_m = Change in MW flow on line m

Since the real power flows on line m and on line ℓ are known, then the post-outage flow on line m with line ℓ out can be determined using LODFs expressed as:

$$\hat{f}_m = f_m^0 + LODF_{m\ell} f_\ell^0 \quad (8)$$

Where

\hat{f}_m = Post-Outage flow on line m with line ℓ out/open

By pre-calculating the LODFs, a very fast procedure can be set up to test all lines in the network for overload for the outage of a particular line. Furthermore, this procedure can be repeated for the outage of each line in turn, with overloads reported to the operations personnel in form of alarm messages.

The LODF matrix is stored such that each row and column correspond to one line in the network, with rows corresponding to monitored line and columns corresponding to the outaged lines. The LODF for a particular outage and monitored transmission line is obtained by finding the monitored line t down the rows and then finding the outaged line ℓ along the row in the appropriate column.

Using the generator and line outage procedures described earlier, one can program a digital computer

to execute a contingency analysis of the power system. For this to be valid, these assumptions must be made. First, it is assumed that the generator output for each of the generators in the system is available and that the line flow for each transmission line in the network is also available; a base case flows (default flow before any contingencies occur) for the transmission lines can be estimated from dc load flow, state estimation techniques or telemetry systems. Second, it assumes that the sensitivity factors calculated and stored are correct. The assumption that the sensitivity factors are correct is valid as long as the transmission network has not undergone any significant switching operations that would change its structure. For this reason, control systems that use sensitivity factors must have provision for updating the factors when the network configuration is altered. A third assumption is that all generation pickup will be made on the reference bus.

V. CASE STUDY RESULTS AND ANALYSES

Case Study Results and Analyses

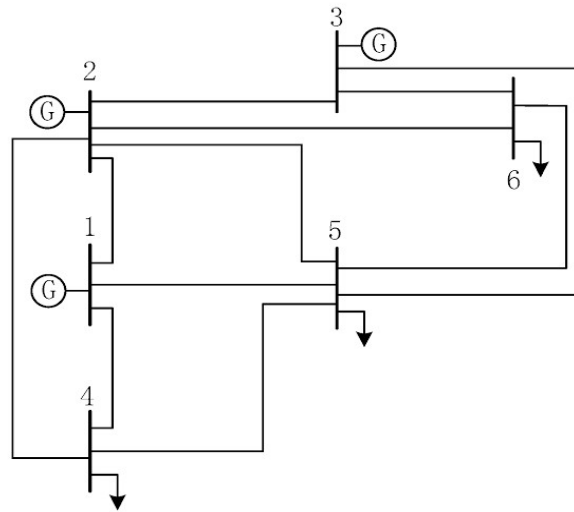

Figure 1: IEEE six bus network one line diagram (Wood A. J., 2014)

Consider the six bus network shown in figure 1 whose bus data, generator data, and line data are given in Tables (1, 2, 3) respectively. The composite table representing the eleven transmission lines real power flows and losses for the base case and contingency cases is given in table 4 and table 5. Table 4 and table 5 shows a comparison between the results gotten from AC load flow calculations and that of DC load flow calculations, on pre contingency scenario and post-contingency scenario. The percentage flow differences between the results from the base case AC and DC power flow are tabulated in table 6 and table 7 respectively. The graphical representation of these percentage differences are shown in figures (2, 3, and 4).

The PTDF and LODF of the base case are given in tables 9 and 11 respectively. Table 9 is observed to have six columns and eleven rows representing the bus and lines respectively, such that the PTDF value (-0.3149) intersecting row 2 and column 2 represents $PTDF_{2,1,1-4}$. PTDF value for the monitored transmission line indexed 2 (placed between bus 1 and bus 4) on account of the outage/contingency of the generation at bus 2 which is transferred to or taken up by the slack bus (bus 1).

Six bus power system data sourced from (Wood A. J., 2014)

Table 1: Bus Data

Bus No.	Bus Type	P _{load} mw	Q _{load} mvar	V _{mag} (pu)	V _{angle} deg	baseKV	V _{max} (pu)	V _{min} (pu)
1	3	0	0	1	0	230	1.07	0.95
2	2	0	0	1	0	230	1.07	0.95
3	2	0	0	1	0	230	1.07	0.95
4	1	100	15	1	0	230	1.07	0.95
5	1	100	15	1	0	230	1.07	0.95
6	1	100	15	1	0	230	1.07	0.95

Key to bus type: 1 = Slack bus, 2 =3=PV bus, 4=5=6= PQ bus

Where PQ bus = Load bus

PV bus = Generator bus

Table 2: Generator Data

Bus no	P _{gen} mw	Q _{gen} mvar	Q _{max} mvar	Q _{min} mvar	V _{gen} deg	MVA _{base}	P _{max} mw	P _{min} mw
1	110	0	150	-100	1.07	100	200	50
2	50	0	150	-100	1.05	100	150	37.5
3	50	0	120	-100	1.05	100	180	45

Table 3: Branch/Line Data

From bus	To bus	Line parameter(pu)			Thermal Limit (mva)	Online Status
		r	x	b		
1	2	0.10	0.20	0.04	100	on
1	4	0.05	0.20	0.04	100	on
1	5	0.08	0.30	0.06	100	on
2	3	0.05	0.25	0.06	60	on
2	4	0.05	0.10	0.02	60	on

2	5	0.10	0.30	0.04	60	on
2	6	0.07	0.20	0.05	60	on
3	5	0.12	0.26	0.05	60	on
3	6	0.02	0.10	0.02	60	on
4	5	0.20	0.40	0.08	60	on
5	6	0.10	0.30	0.06	60	on

Table 4: Base case flow result showing flows and losses

		Base Case					
		AC Load Flow			DC Load Flow		
		From	To	Real Flow (MW)	Loss (MW)	Real Flow (MW)	Loss (MW)
Line index	Bus	Bus					
1	1	2	62.18	3.6	60.65	0	
2	1	4	82.8	3.023	76.66	0	
3	1	5	67.98	3.247	62.69	0	
4	2	3	14.76	0.102	13.68	0	
5	2	4	28.86	0.421	32.03	0	
6	2	5	21.94	0.455	22.26	0	
7	2	6	43.01	1.175	42.67	0	
8	3	5	12.43	0.203	12.54	0	
9	3	6	52.23	0.549	51.14	0	
10	4	5	8.21	0.141	8.69	0	
11	5	6	6.63	0.049	6.18	0	
	Gen		312.96		300		
	Load		300		300		
	Loss		12.965		0		

Table 5: flow after contingency of line index 6 and contingency of generator 2

Line index	Contingency of Line index 6				Contingency of Generator 2			
	AC Load flow		DC Load Flow		AC Load flow		DC Load Flow	
	Real Flow (MW)	Loss (MW)	Real Flow (MW)	Loss (MW)	Real Flow (MW)	Loss (MW)	Real Flow (MW)	Loss (MW)
1	57.95	3.116	55.96	0	87.67	6.825	84.18	0
2	81.54	2.942	75.28	0	100.41	4.502	92.4	0
3	74.16	3.896	68.75	0	80.55	4.579	73.42	0
4	20.34	0.193	18.72	0	12.94	0.159	10.96	0
5	35.23	0.599	38.64	0	12.33	0.097	16.46	0
6	0	0	0	0	16.32	0.254	17.3	0
7	49.27	1.541	48.61	0	39.25	1.066	39.46	0
8	18.52	0.439	18.29	0	9.94	0.24	9.43	0
9	51.63	0.557	50.43	0	52.85	0.637	51.53	0
10	13.23	0.344	13.92	0	8.14	0.159	8.86	0
11	1.22	0.02	0.96	0	9.72	0.111	9.01	0
Gen	313.65		300	0	318.63		300	0
Load	300		300	0	300		300	0
Loss	13.647		0	0	18.629		0	0

Table 6: Base case AC power flow result by percentage

LINE INDEX	AC	AC%
1	62.18	15.50507
2	82.8	20.64683
3	67.98	16.95135
4	14.76	3.680523
5	28.86	7.196469
6	21.94	5.470912
7	43.01	10.72488
8	12.43	3.099519
9	52.23	13.02396
10	8.21	2.047228
11	6.63	1.653243
TOTAL	401.03	100

Table 7: Base case DC power flow result by percentage

LINE INDEX	DC	DC%
1	60.65	15.58365
2	76.66	19.69732
3	62.69	16.10781
4	13.68	3.514993
5	32.03	8.229913
6	22.26	5.719571
7	42.67	10.9638
8	12.54	3.222077
9	51.14	13.14011
10	8.69	2.232843
11	6.18	1.587913
TOTAL	389.19	100

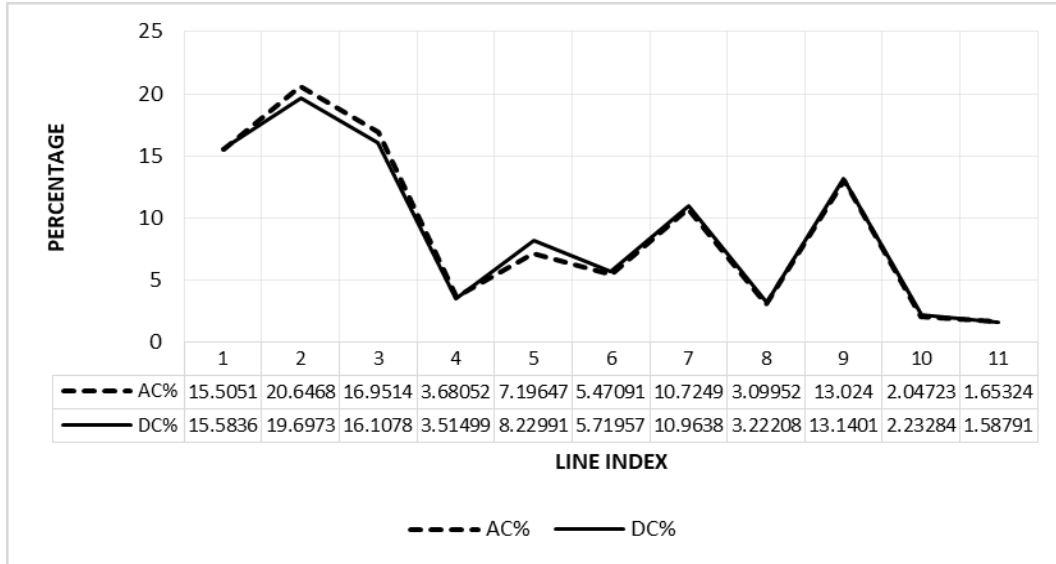

Figure 2: graphical representation of the base case power flow result

Consider the DC columns of table 7 where the base case power flow on line indexed 2 is 76.66 MW. With the transfer of 50MW from generator at bus 2 to bus 1, the change of power at bus 2 is $\Delta P = 0 - 50$. If the real power flow on line indexed 2 is desired, then using

$$\hat{f}_2 = f_2^0 + PTDF_{2,1,2} \Delta P \tag{10}$$

$t = 2$: Monitored transmission line index

$i = 2$: Bus where power is taken out (contingency bus)

$ref = 1$: Bus where power is injected (post-contingency bus)

$\Delta P = -50$: Change in power at bus i

$PTDF_{2,1,2} = -0.3149$: Intersect of row 2 and column 2 of table 9

The Outage flow on line indexed 2, becomes

$$\hat{f}_2 = 76.66 + (-0.3149)(-50) = 92.41 \text{ MW}$$

As calculated for the line indexed 2, the real power flow on account of the contingency of generator at bus 2 as solved with the PTDF is observed to be the same with DC load flow result presented in table 7. Assume that the generator at bus 2 reduced its output from 50MW to 35MW and the slack bus picked up the reduced generation in order to serve the unchanged load of 300MW, then using the PTDF sensitivity, the real power flow on any monitored line can be predicted. As illustrated previously, all terms remain same except that $\Delta P = 35 - 50 = -15$. Change in power at bus 2

$$\hat{f}_2 = 76.66 + (-0.3149)(-15) = 81.38 \text{ MW}$$

Table 8: Power flow result after generator 2 contingency

LINE INDEX	AC	AC%	DC	DC%
1	87.67	20.38268	84.18	20.38207
2	100.41	23.34465	92.4	22.37234
3	80.55	18.72733	73.42	17.77681
4	12.94	3.008463	10.96	2.653689
5	12.33	2.866642	16.46	3.985376
6	16.32	3.79429	17.3	4.188761
7	39.25	9.12536	39.46	9.554248
8	9.94	2.310983	9.43	2.283238
9	52.85	12.28727	51.53	12.4767
10	8.14	1.892495	8.86	2.145227
11	9.72	2.259834	9.01	2.181545
TOTAL	430.12	100	413.01	100

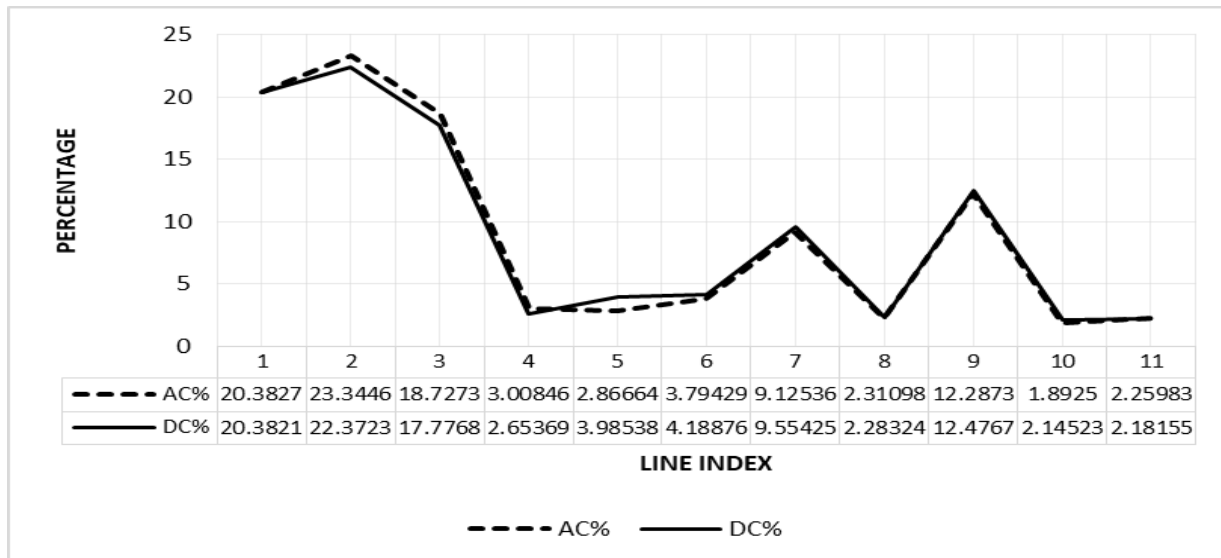

Figure 3: graphical representation of the power flow as a result of contingency of generator 2

Table 8: Base Case and Contingency Generator Output

Bus No	Load (MW)	Base Case		Gen. 2 Contingency		Gen. 2 Output Reduction		Line 2 Contingency	
		AC Gen. (MW)	DC Gen. (MW)	AC Gen. (MW)	DC Gen. (MW)	AC Gen. (MW)	DC Gen. (MW)	AC Gen. (MW)	DC Gen. (MW)
1	-	212.96	200	268.63	250	229.41	215	213.65	200
2	-	50	50	-	-	35	35	50	50
3	-	50	50	50	50	50	50	50	50
4	100	-	-	-	-	-	-	-	-
5	100	-	-	-	-	-	-	-	-
6	100	-	-	-	-	-	-	-	-

Table 9: PTDF for the base case of the six bus network

PTDF Line Index	Bus From – To	Contingency Buses					
		Bus1	Bus2	Bus3	Bus4	Bus5	Bus6
Line1	1 – 2	0	-0.4706	-0.4026	-0.3149	-0.3217	-0.4064
Line2	1 - 4	0	-0.3149	-0.2949	-0.5044	-0.2711	-0.2960
Line3	1 - 5	0	-0.2145	-0.3026	-0.1807	-0.4072	-0.2976
Line4	2 - 3	0	0.0544	-0.3416	0.0160	-0.1057	-0.1907
Line5	2 - 4	0	0.3115	0.2154	-0.3790	0.1013	0.2208
Line6	2 - 5	0	0.0993	-0.0342	0.0292	-0.1927	-0.0266
Line7	2 - 6	0	0.0642	-0.2422	0.0189	-0.1246	-0.4100
Line8	3 - 5	0	0.0622	0.2890	0.0183	-0.1207	0.1526
Line9	3 - 6	0	-0.0077	0.3695	-0.0023	0.0150	-0.3433
Line10	4 - 5	0	-0.0034	-0.0795	0.1166	-0.1698	-0.0752
Line11	5 – 6	0	-0.0565	-0.1273	-0.0166	0.1096	-0.2467

If we desire to know the fraction of real power that flows on a monitored line say line index 8 (m=8) as a result of the outage of line index 6 (l=6), then using equation 7

$$LODF_{m,l} = \frac{\Delta f_m}{f_l^0}$$

Where

$LODF_{m,l} = LODF_{8,6}$ = Line outage distribution factor of the monitored line $m = 8$ after an outage of line $l = 6$

f_l^0 = Pre-contingency/pre-outage flow on line l before it was outaged (opened)

$\Delta f_m = \bar{f}_m - f_m^0$ Change in MW flow on line m

\bar{f}_m = Post-Outage flow on line m with line l out/open

f_m^0 = Pre-contingency/pre-outage flow on line m , before line e was outaged (opened)

From table 7, $f_f^0 = f_g^0 = 22.26\text{MW}$, $f_m^0 = f_g^0 = 12.54\text{MW}$, $f_m^- = f_g^- = 18.29\text{MW}$,

$$\therefore \Delta f_m = 18.29 - 12.54 = 5.75\text{MW}$$

$$\text{LODF}_{8,6} = \frac{\Delta f_g}{f_g^0} = \frac{5.75}{22.26} = 0.25831$$

Table 10: power flow after contingency of line 6

LINE INDEX	AC	AC%	DC	DC%
1	57.95	14.37644	55.96	14.36492
2	81.54	20.22873	75.28	19.32437
3	74.16	18.39788	68.75	17.64812
4	20.34	5.046019	18.72	4.805422
5	35.23	8.739984	38.64	9.918883
6	0	0	0	0
7	49.27	12.22308	48.61	12.47818
8	18.52	4.594507	18.29	4.695041
9	51.63	12.80855	50.43	12.94537
10	13.23	3.282145	13.92	3.573262
11	1.22	0.302662	0.96	0.246432
TOTAL	403.09	100	389.56	100

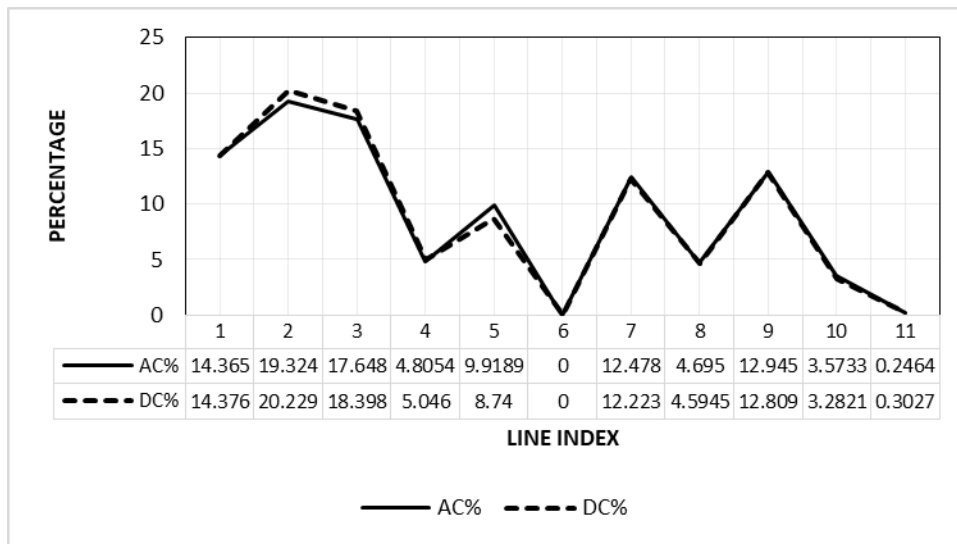

Figure 4: graphical representation of power flow after contingency of line 6

This LODF value can be found at the intersect of the eighth row with the sixth column of table 11. This table contains all LODF values for the eleven transmission lines when monitored with respect to the outage of any line including itself. The values in this table can then be used to predict the flow on any

transmission line due to an outage of another line with respect to the base case operating point.

Therefore the post-outage flow on the monitored line can be gotten using

$$\bar{f}_m = f_m^0 + LODF_{m,i} f_i^0 \tag{4}$$

Table 11: LODF for the base case of the six bus network

LODF m.line	Contingency/Outaged Lines										
	Line1	Line2	Line3	Line4	Line5	Line6	Line7	Line8	Line9	Line10	Line11
Line1	-1.000	0.6353	0.5427	-0.1127	-0.5031	-0.2103	-0.1221	-0.1369	0.0135	0.0096	0.1316
Line2	0.5948	-1.000	0.4573	-0.0331	0.6121	-0.0618	-0.0359	-0.0403	0.0040	-0.3269	0.0387
Line3	0.4052	0.3647	-1.000	0.1458	-0.1090	0.2721	0.1580	0.1772	-0.0174	0.3174	0.1703
Line4	-0.1029	-0.0323	0.1783	-1.0000	0.1242	0.2262	0.4662	-0.3995	-0.5253	0.1706	0.1320
Line5	-0.5884	0.7647	-0.1708	0.1591	-1.0000	0.2969	0.1724	0.1933	-0.019	-0.6731	0.1858
Line6	-0.1875	-0.0589	0.3250	0.2209	0.2264	-1.0000	0.2394	0.2685	-0.0264	0.311	-0.2580
Line7	-0.1213	-0.0381	0.2102	0.5073	0.1464	0.2667	-1.0000	-0.1992	0.5842	0.2011	0.4433
Line8	-0.1175	-0.0369	0.2036	-0.3755	0.1418	0.2583	-0.1720	-1.0000	0.4747	0.1948	-0.4246
Line9	0.0146	0.0046	-0.0253	-0.6245	-0.0176	-0.0321	0.6382	0.6005	-1.000	-0.0242	0.5567
Line10	0.0065	-0.2353	0.2865	0.1259	-0.3879	0.2350	0.1365	0.1530	-0.015	-1.000	-0.1471
Line11	0.1067	0.0335	-0.1849	0.1172	-0.1288	-0.2346	0.3618	-0.4013	0.4158	-0.1769	-1.000

m.line = monitored transmission line

If from a reference operating point of a power system, it is desired to predict the real power flow on network similar to table 11 for the six bus system becomes handy.

The LODF for a monitored transmission line on account of a particular outage is obtained by locating the monitored line m along the rows of the LODF matrix and then tracing the outaged line i along the row to the appropriate column. For instance, the LODF that gives the fraction of flow picked up on line indexed 8 (between bus 3 and bus 5) for an outage on line indexed 9 (between bus 3 and bus 6) is found in the eighth row and ninth column and has the value 0.4747. The outage flow on line indexed 8 is 36.81MW.

From the six bus power system, when the generator at bus 2 was taken out and the lost generation was compensated by the reference generator at bus 1, the pre contingency power flow on line index 2 which is the line between bus 1 and bus 4 was 76.66MW. After the post contingency generation transfer of 50MW from bus 2 to bus 1, the real power flow on

a monitored transmission line following the outage of another line, then the sensitivity factor LODF for the line index 2 was calculated using PTDF sensitivity factor to determine the effect of the post contingency generation transfer from bus 2 to bus 1. The study found that due to this change at bus 2, the sensitivity factor $PTDF_{2,1}$ obtained as -0.3149 from table 9 which represents the proportion of power that will flow between bus 2 to bus 1 as a result of a contingency, the line index 2 real power increased from 76.66MW to 92.41MW. The study compared the value obtained using PTDF sensitivity factor method and the value from DC load flow calculation method and discovered it to be of the same value. This obtained value was found to be close to the operating thermal limit of the line which is 100MVA.

Similarly the output generation at bus 2 was reduced from 50MW to 35MW, the study found out that due to this variation or drop in bus 2 generation output, the MW flow on line index 2 which was 76.66MW before generation drop became 81.38MW as calculated also using the PTDF sensitivity factor. Even though this is an incremental change in power

flow on line index 2, the value is still within the acceptable operating limit. Thus the severity of line index 2 and other line indexes to variation on buses should be monitored closely in order to keep the line secure and safe from increasing beyond its default thermal limit.

The PTDF and LODF values ranges from negative one (-1) to positive one (+1). The more these values tend towards -1 or +1, the more sensitive a line will be in reaction to a generation outage or output reduction or an outage of another line. VI.

VI. CONCLUSION

A The use of linear sensitivity factors in the form of power transfer distribution factor (PTDF) and line outage distribution factor (LODF), greatly reduces the computational work of power system analysis. This study has shown that linear sensitivity factor technique unlike the conventional methods of power system analysis, could be used to predict the post contingency line flow in a linear non-iterative manner, and still gives the same results as the conventional power flow analysis techniques which requires more calculations.

The study found the proportionality of power that will flow on a monitored transmission line, as a result of a change in power flow due to a contingency. The power transfer distribution factor and the line outage distribution factor PTDF and LODF respectively, were developed and used to ascertain the actual real time power flow on the transmission line after a contingency.

The study did a comparison between the AC and DC power flow analysis result and found out that the percentage flow rate of each technique is approximately the same. It also showed that transmission line flow estimates are possible using DC load flow technique for quick estimation of transmission line flows. However, the use of PTDF and LODF linear sensitivity factors to estimate transmission line flows from a known operation point yields faster result that matches in exactness with the estimations from DC power flow analysis.

These sensitivity factors in the form of PTDF and LODF are calculated and stored for a network, and it

remains valid for use as long as the network is unmodified with the addition of bus, loads, generator or transmission line.

From any known operation point, the transmission line flow or loading/overloading of any other operation point following the outage or variation of generator power output or the contingency of a transmission line may be estimated using the stored network values of PTDF and LODF. Unlike transmission flow results derived from AC techniques, PTDF and LODF flow estimates are not only non-iterative but linear and has the exact value with flows from DC load flow analysis.

The study proposed a sensitivity analysis expression that can relate to expected real time load value in relation to component variations as well as operating limit verification. Using the proposed PTDF and LODF linear sensitivity factors, the actual load flow on the transmission line can be estimated acutely, and the results will still tally with the eventual result after a contingency.

REFERENCES

- [1] Allen, B. (2005). In B. F. Allen J. Wood, Power Generation Operation and Control, Singapore: John Wiley and Sons.2nd Ed (pp. 328-362).
- [2] Ameze, A. O. (2013). Transient stability assessment of the Nigerian 330kv network. International Journal of Engineering,(IJE), Vol. 4, Issue. 5, 32-37.
- [3] Ben-Idris, M. (2014). Application of Sensitivity Analysis in Planning and Operation of Modern Power Systems. Michigan: Michigan State University.
- [4] Chao Zhai, H. Z.-C. (2018, September 13). Modeling and Identification of Worst-Case Cascading Failures in Power system. Retrieved from [arxiv.org: https://arxiv.org/abs/1703.05232](https://arxiv.org/abs/1703.05232)
- [5] Chong, S. S. (2011). Implementation of ptdfs and lodfs for Power System Security. Journal of International Council of Electrical Engineering,, 1(1), 49-53.
- [6] Harcourt, H. M. (2018, September 10). American Heritage. Retrieved from Dictionary

- of the English Language, Fifth Edition:
<https://www.thefreedictionary.com/sensitivity>
- [7] Allen, B. (2005). In B. F. Allen J. Wood, Power Generation Operation and Control, Singapore: John Wiley and Sons.2nd Ed (pp. 328-362).
- [8] Ameze, A. O. (2013). Transient stability assessment of the Nigerian 330kv network. International Journal of Engineering,(IJE), Vol. 4, Issue. 5, 32-37.
- [9] Ben-Idris, M. (2014). Application of Sensitivity Analysis in Planning and Operation of Modern Power Systems. Michigan: Michigan State University.
- [10] Chao Zhai, H. Z.-C. (2018, September 13). Modeling and Identification of Worst-Case Cascading Failures in Power system. Retrieved from [arxiv.org: https://arxiv.org/abs/1703.05232](https://arxiv.org/abs/1703.05232)
- [11] Chong, S. S. (2011). Implementation of ptdfs and lodfs for Power System Security. Journal of International Council of Electrical Engineering,, 1(1), 49-53.
- [12] Harcourt, H. M. (2018, September 10). American Heritage. Retrieved from Dictionary of the English Language, Fifth Edition: <https://www.thefreedictionary.com/sensitivity>
- [13] James Onojo, K. I. (2016). A Comparative Study Of The Contingency Assessment Of The Reformed Nigeria 330kv Power Network Under Normal And Fortified Conditions. International Journal of Electrical and Electronics Engineering Studies Vol.3, No.1,, 1-13.
- [14] Lakshya Bhat, A. S. (2015). Sensitivity Analysis for 14 Bus Systems in a Distribution Network With Distributed Generators. IOSR Journal of Electrical and Electronics Engineering (IOSR-JEEE) e-ISSN: 2278-1676,p-ISSN: 2320-3331, Volume 10, Issue 3 Ver. I, 21-27.
- [15] Teoman, G. G. (2007). Generalized Line Outage Distribution Factor. IEEE Trans. Power Systems, 27 (2), 879-881.
- [16] William Rosa, E. A. (2014). First-Order Sensitivity Applied in Power Distribution System. PRZEGLĄD ELEKTROTECHNICZNY, ISSN 0033-2097, R. 90, 94-98.
- [17] Wood, A. J. (2014). Power Generation. Operation and Control, 3rd Edition. New York: John Wiley, 243-343.
- [18] Wood, W., & Sheble. (2014). Power Generation. Operation and Control, 3rd Edition. New York: John Wiley, 243-343.